

WHEN DISASSEMBLING ALUMINUM EXTRUSION, TIGHTEN ALL SETSCREWS AND LOCKS TO PREVENT LOSS DURING SHIPPING

visionary™ IDESIGNS

Using Your Setup Instructions

The Visionary Designs Setup Instructions are created specifically for your configuration. They are laid out sequentially, including an exploded view of the entire display, and then a logical series of detailed steps to assemble the main structure and components. We encourage you to study the instructions **before** attempting to assemble your exhibit.

Each page reminds you to tighten the setscrews after disassembling your exhibit to prevent loss of the locks and setscrews (see below in RED). This is **VERY IMPORTANT**.

Cleaning and Packing Your Display

- 1) Use care when cleaning aluminum extrusion or acrylic inserts. Use only non-abrasive cleaners.
- 2) When cleaning laminate inserts or countertops, use mild cleansers and a soft material such as cotton.
- 3) Keep all display components away from extreme heat and long exposure to sunlight to avoid warping and fading.
- 4) Retain all packing material. It will make re-packing much easier and will reduce the likelihood of shipping damage.



The Tool

Most Visionary Designs exhibits can be assembled with the supplied Hex Key Tool. Occasionally, a flat head screwdriver may be required.



Detail A

Typical Connection



Typical Connection (cont'd)

Most horizontal extrusion connections have a patented expandable lock. This lock inserts into the groove of an opposing extrusion. Tightening the lock with the Hex Key Tool expands the lock and creates a strong positive connection.

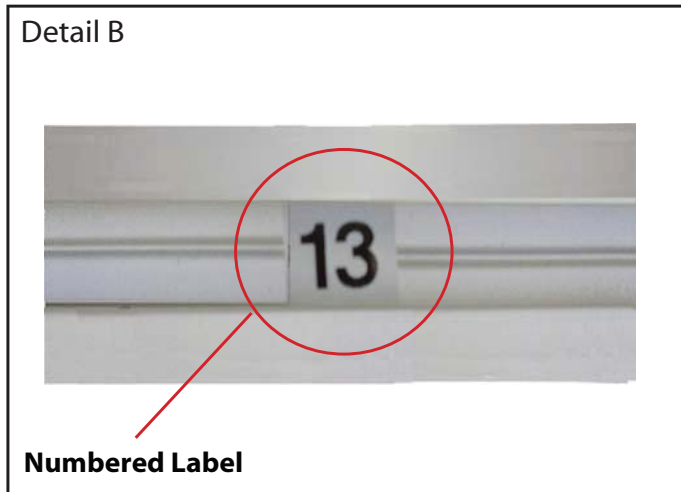

Detail B

Numbered Label

Each extrusion contains a numbered label which corresponds with setup instructions. The label is located within a groove of the extrusion (when possible). With Visionary Designs the labels contain Black numbers unless otherwise specified.



Detail C

Horizontal Inline Connection (remove only one setscrew)

Remove only (1) setscrew when disassembling. Replace setscrew in extrusion after assembling it. Before packing, replace setscrew in extrusion to avoid losing it.

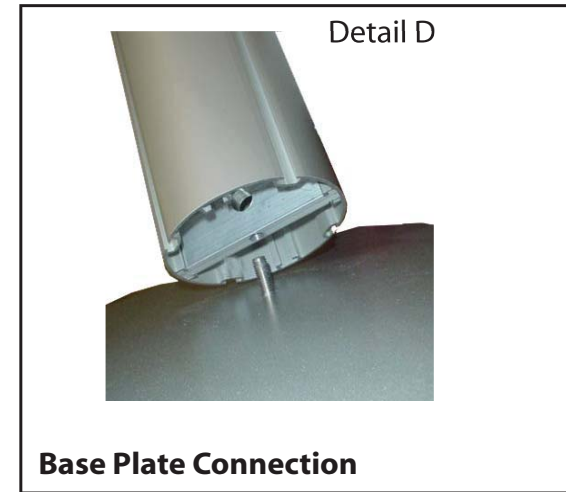

Detail D

Base Plate Connection

Attach base plate to round or square vertical extrusion using the bolt provided. Be careful not to strip the threads.

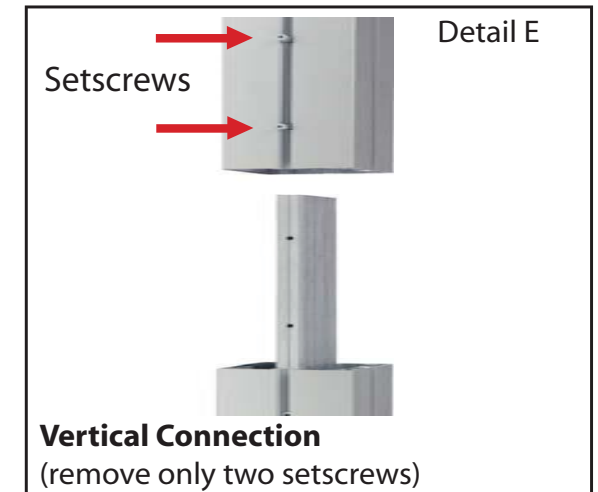

Detail E

Vertical Connection
(remove only two setscrews)

When vertical extrusions are packed in portable cases rather than crates or tubs, they must be broken down into smaller sections which then require assembly.

Remove only (2) setscrews when disassembling. Replace setscrews in extrusion after assembling it. Before packing, replace setscrews in extrusion to avoid losing them.

WHEN DISASSEMBLING ALUMINUM EXTRUSION, TIGHTEN ALL SETSCREWS AND LOCKS TO PREVENT LOSS DURING SHIPPING

866.652.2100

| Item | Quantity | Description |
|-------|----------|---|
| 1 | 4 | Oval Base Plates |
| 2 | 2 | 42" Square Vertical Extrusion |
| 3 | 2 | 42" Square Vertical Extrusion |
| 4 | 2 | 42" Square Vertical Extrusion |
| 5 | 2 | 42" Square Vertical Extrusion with Canopy Attachments |
| 6A/6B | 2/2 | 36.125" Curved Horizontal Extrusion w/ Velcro Attached to Top of Extrusion |
| 7A/7B | 2/2 | 36.125" Curved Horizontal Extrusion w/ Velcro Attached to Bottom of Extrusion |
| 8A/8B | 1/1 | 42" Horizontal Extrusion Velcro Attached to Top of Extrusion |
| 9A/9B | 1/1 | 42" Horizontal Extrusion Velcro Attached to Bottom of Extrusion |
| 10 | 4 | 40" Round Vertical Extrusion |
| 11 | 4 | 19" Tapered Horizontal Extrusion |

Steps:

- 1) Attach base plates 1 to vertical extrusions 2 and 3.
- 2) Attach extrusions 10 to base plates 1 as shown.
- 3) Assemble vertical extrusions; attach 4 to 2 and 5 to 3.
- 4) Assemble horizontal extrusions as shown: attach 6A to 6B; 7A to 7B; 8A to 8B; and 9A to 9B.
- 5) Attach assembled horizontal extrusions to assembled vertical extrusions as shown.
- 6) Attach horizontal extrusions 11 between vertical extrusions 2 or 3 and round vertical extrusions 10, as seen below.
- 7) Place counters atop extrusions 11, with notch toward the square vertical extrusions, then tighten thumbscrews.



Note: Attaching Graphics

Attach Backwall Graphics to Velcro by wrapping the Graphic over the Top of the Upper Horizontals and under the Bottom of the Lower Horizontals

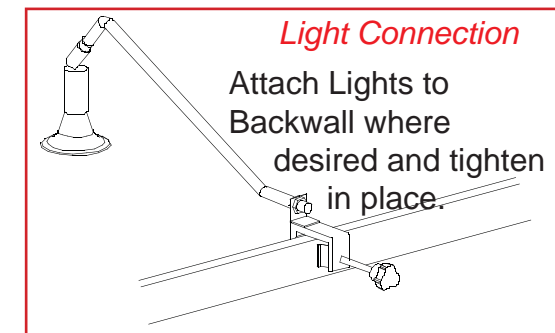
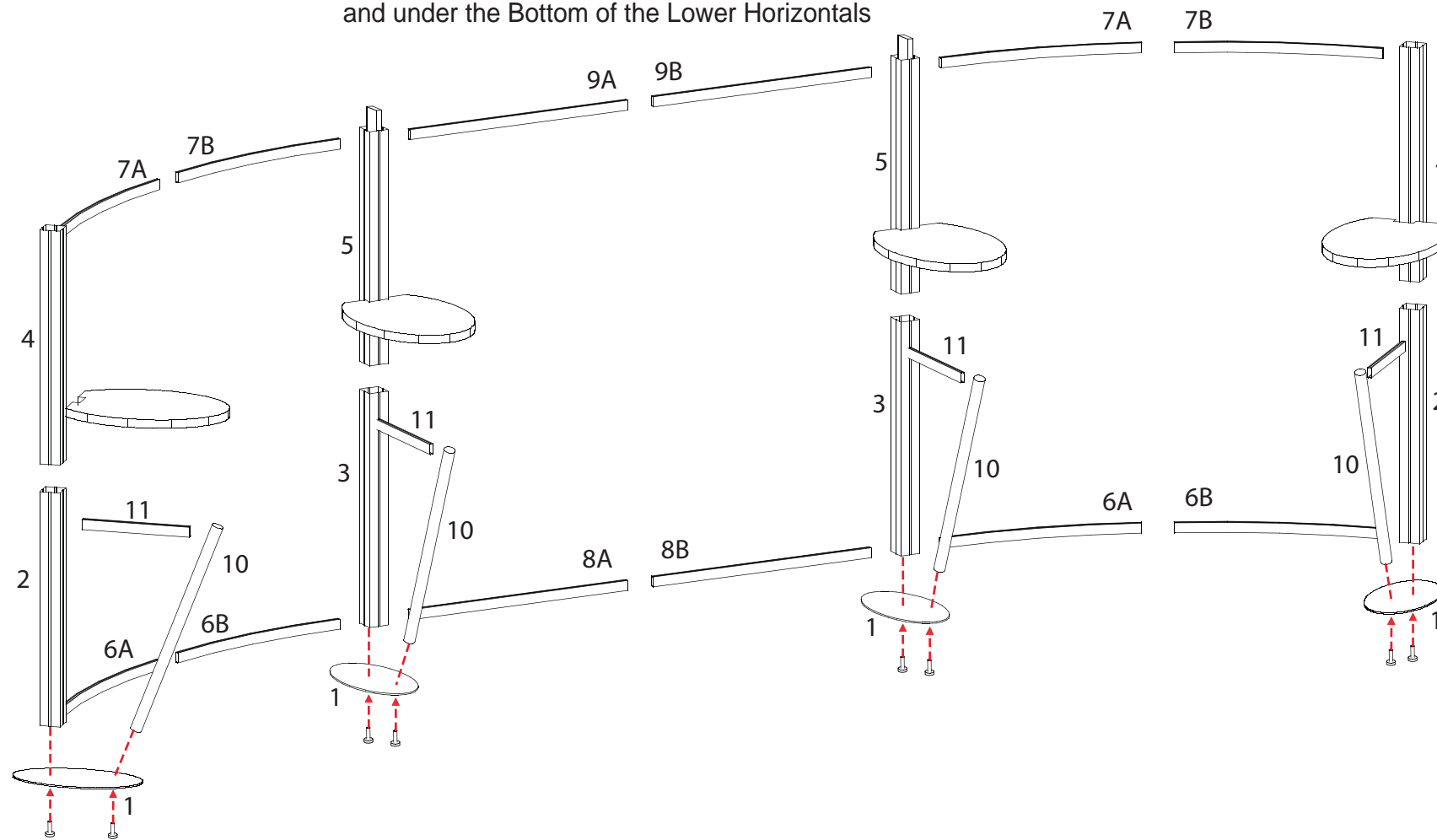

WHEN DISASSEMBLING ALUMINUM EXTRUSION, TIGHTEN ALL SETSCREWS AND LOCKS TO PREVENT LOSS DURING SHIPPING

866.652.2100

| Item | Quantity | Description |
|------|----------|----------------------------|
| A | 1 | 39" Round curved extrusion |
| AB | 1 | 39" Round curved extrusion |
| B | 1 | 39" Round curved extrusion |
| C | 1 | 39" Round curved extrusion |
| CD | 1 | 39" Round curved extrusion |
| D | 1 | 39" Round curved extrusion |
| E | 2 | 14" Round extrusion |
| F | 1 | 14" Round extrusion |

Steps:

- 1) Connect 39" (A) round formed extrusion to 39" (A) round formed extrusion.
- 2) Connect 39" (B) round formed extrusion to 39" (B) round formed extrusion.
- 3) Connect 39" (C) round formed extrusion to 39" (C) round formed extrusion.
- 4) Connect 39" (D) round formed extrusion to 39" (D) round formed extrusion.
- 5) Connect (A) round formed extrusion and (D) round formed extrusion to 14" (E) extrusion.
- 6) Connect (B) round formed extrusion and (C) round formed extrusion to 14" (E) extrusion.
- 7) Connect (AB) round formed extrusion and (CD) round formed extrusion to 14" (F) extrusion.
- 8) Attach Canopy Assembly to Vertical extrusions with Canopy attachments.

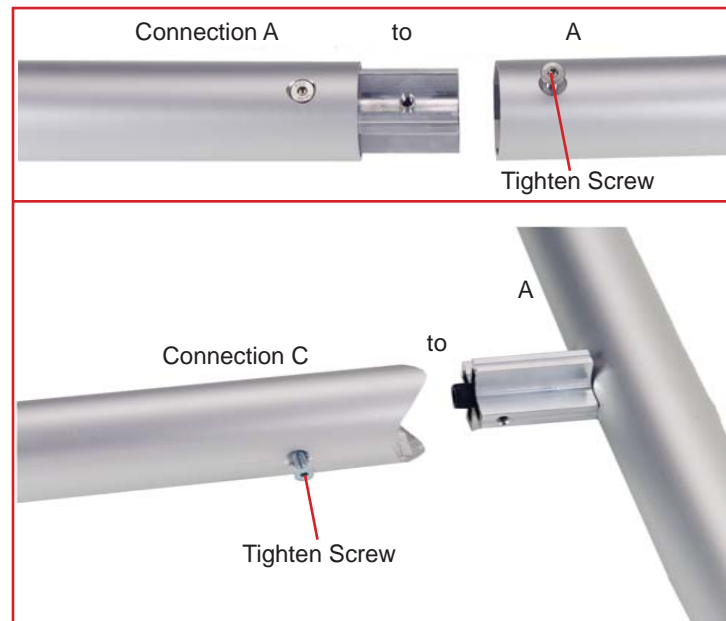
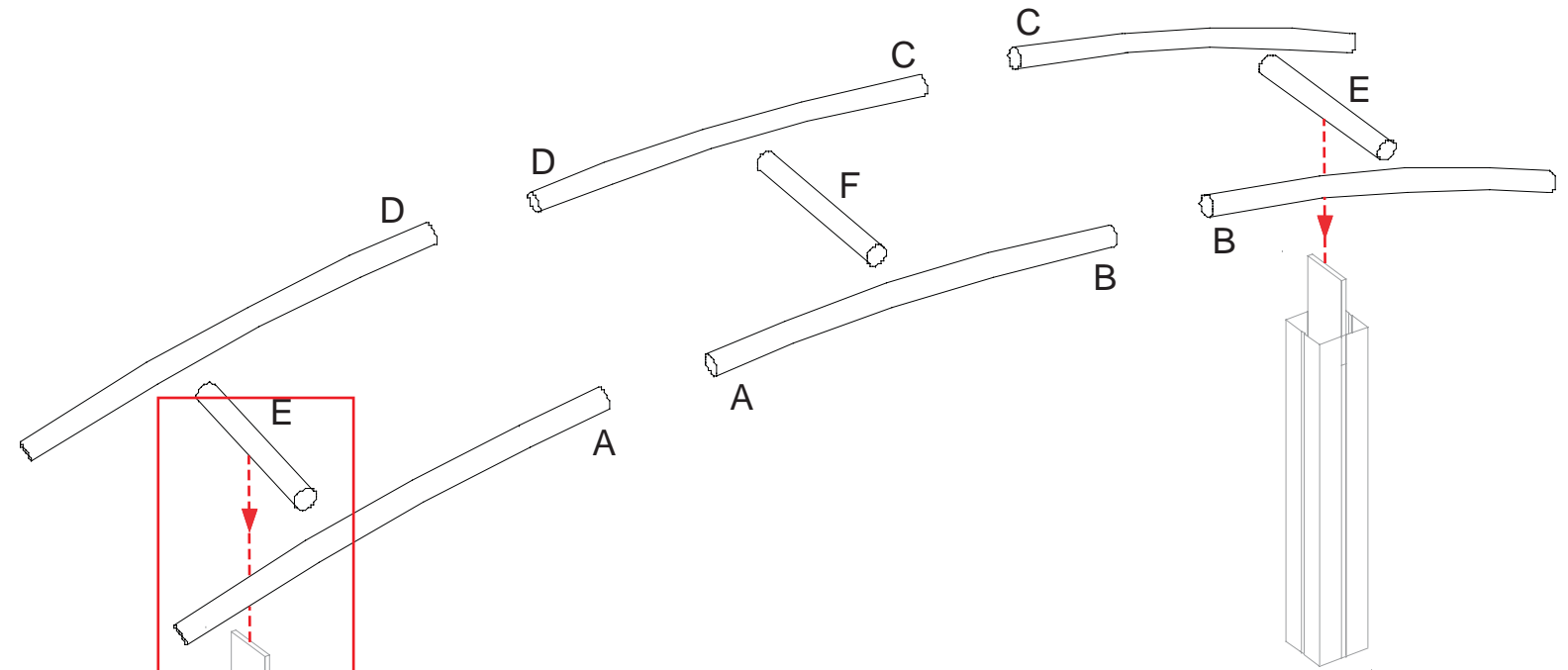

Canopy Connection

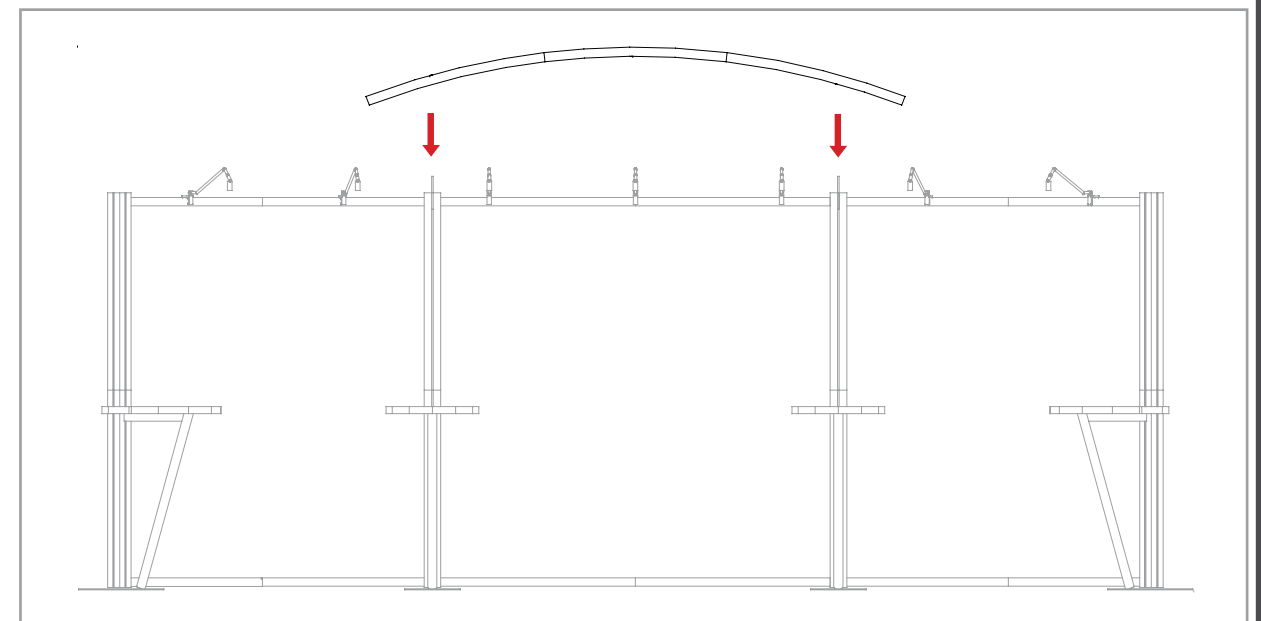

WHEN DISASSEMBLING ALUMINUM EXTRUSION, TIGHTEN ALL SETSCREWS AND LOCKS TO PREVENT LOSS DURING SHIPPING

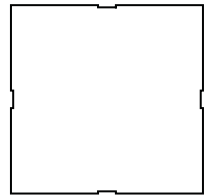

42”h Square Extrusion

Qty. : 8

Located in Case : _____

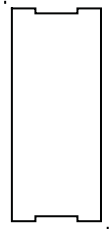

42”h Extrusion

Qty. : 4

Located in Case : _____

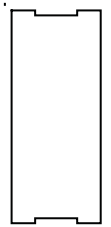

Curved Extrusion

Qty. : 8

Located in Case : _____

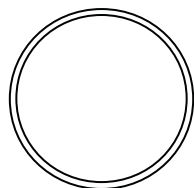

Tapered Counter Support

Qty. : 2

Located in Case : _____

Tapered Counter Support

Qty. : 2

Located in Case : _____

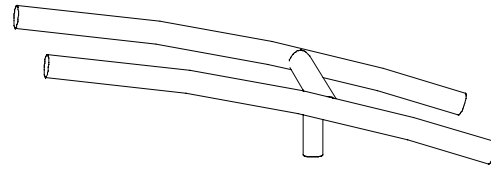

Curved Standard Canopy Piece

Located in Case : _____

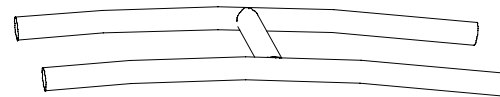

Curved Standard Canopy Piece

Located in Case : _____

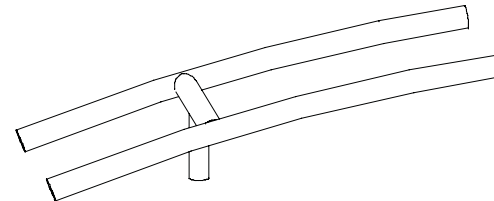

Curved Standard Canopy Piece

Located in Case : _____

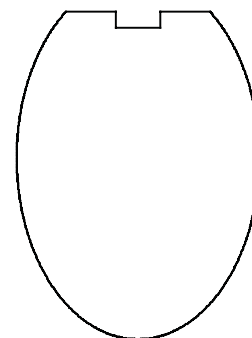

Workstation Counter Top

Qty. : 2

Located in Case : _____

Workstation Counter Top

Qty. : 2

Located in Case : _____

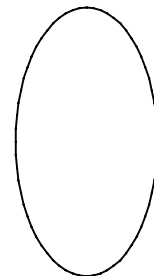

Oval Base Plate

Qty. : 2

Located in Case : _____

Oval Base Plate

Qty. : 2

Located in Case : _____

Additional Accessories:

_____ Graphic _____ in case _____

_____ Setup Hardware _____ in case _____

_____ in case _____

_____ in case _____

_____ in case _____

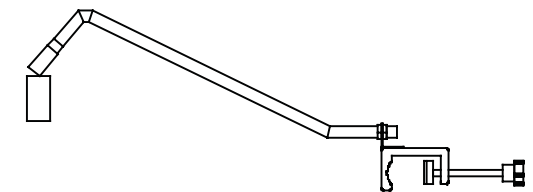

Halogen Light

Qty. : 7

Located in Case : _____

WHEN DISASSEMBLING ALUMINUM EXTRUSION, TIGHTEN ALL SETSCREWS AND LOCKS TO PREVENT LOSS DURING SHIPPING